

# INDIRECT WATER COOLING TYPE (WD)

The resistors are designed to be indirectly cooled with water running through the water-cooled block assembled on the both sides of the resistors. In view of the current trend to exploit the large power applied circuits with semiconductors, demands are increasingly getting higher for non-inductive resistors with a compact design but a large energy capacity. WDs connected in series or in parallel will comply with the requirements on the voltage and current load.

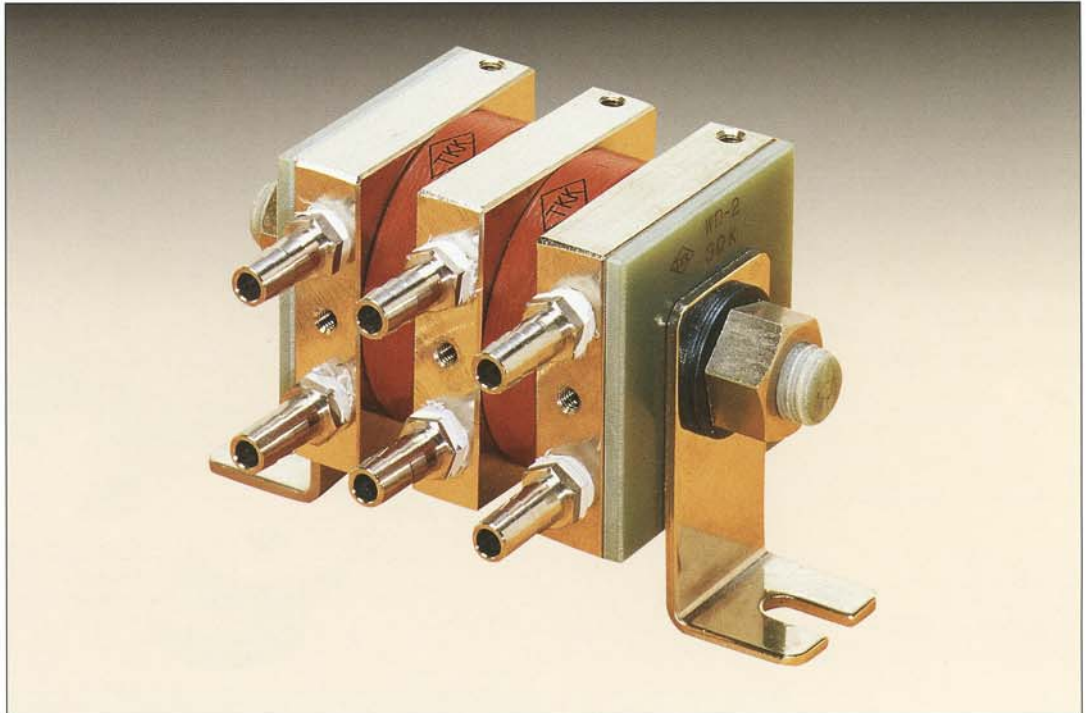

## TYPICAL APPLICATIONS:

- (1) Surge absorber of high frequency thyristor inverter
- (2) Load resistor of high voltage circuits
- (3) Dumping resistor of the nuclear fusion
- (4) Large capacity load resistor

## CHARACTERISTICS:

Item	Characteristics of individual resistor used for WD
Individual resistor:	ASW7515
Element dimensions:	$\phi 75 \times \phi 20 \times 15 \text{mm}$
Bulk density:	2.2~2.7
Specific heat:	630~1250 J/(kg·K)
Thermal conductivity:	1.2 W/(m·k)

Item	Characteristics of individual resistor used for WD
Thermal coefficient:	-0.05~0.1%/°C Max
Thermal expansion coefficient:	$4 \sim 7 \times 10^{-6}$
Max working temperature:	250°C
Allowable injection energy:	10 kJ Max
Allowable current:	800 A Max

● Stainless steel hose joints shown above or Swageloks can be assembled.

## FEATURES:

- (1) No water leakage
- (2) Short time rating power is as large as 500 W per element.
- (3) Large absorbing energy
- (4) Higher withstand voltage. 10 kV per element at 1.2 x 50  $\mu\text{s}$  waveform
- (5) Mounting legs are insulated from elements.
- (6) Non-inductive resistor
- (7) Large current capacity due to the large cross-sectional area of the element.

## WD STANDARD SPECIFICATIONS:

Type No.	Rated Power (W)	Element Qty	Dimensions (mm)			Resistance Range ( $\Omega$ )		Allowable Injection Energy (J)
			A	B	C	Min	Max	
WD-1	350	1	61	110	131	0.5	20	10k
WD-2	770	2	94	143	164	1	40	20k
WD-3	1050	3	127	176	197	1.5	60	30k
WD-4	1400	4	160	209	230	2	80	40k
WD-5	1750	5	193	242	263	2.5	100	50k

### NOTES:

- (1) Water is to be inputted at 3 L/min minimum and 0.59 Mpa maximum.
- (2) Use a hose with  $\phi 3/8$  inch ID.
- (3) Use pure water of 1 M $\Omega$  minimum.

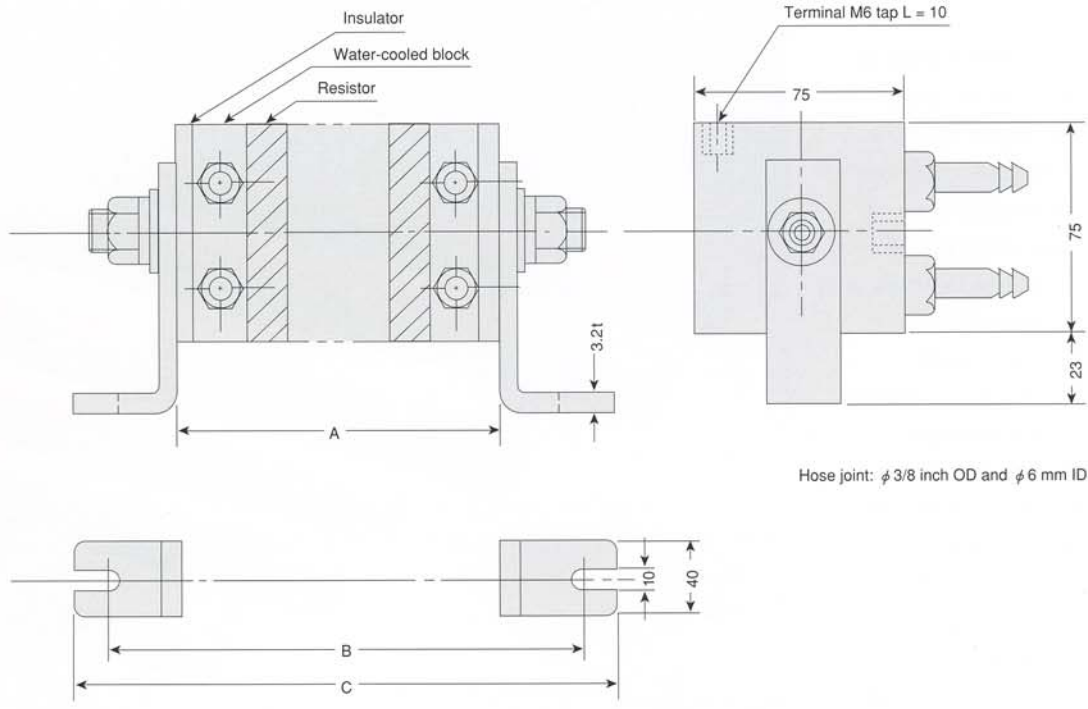

Hose joint:  $\phi$  3/8 inch OD and  $\phi$  6 mm ID

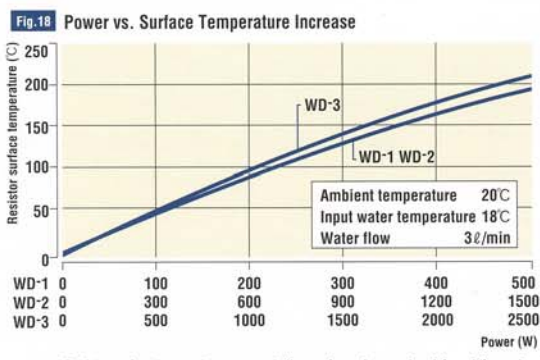

Resistor surface temperature represents the maximum temperature taken at the center of the upper surface of the element on the water outlet side.

