

# Ultra High Power Resistors

## Series NXP 600 (Very low component height)

600 Watt Resistor (up to 800 Watt), US Patent # 5,355,281

For variable speed drivers, power supplies, control devices, robotics, motor control and other power designs.

### General Characteristics

Electric support:

- High purity ceramic metallized with EBG ALTOX film on the bottom for better heat transfer and optimum discharge.

Encapsulation:

- Special resin filled epoxy casing. High insulation resistance (CTI 600), high dielectric strength and partial discharge capability.

Resistance Element:

- Special design for low inductance and capacitance values. The element employs our special METOXFILM which demonstrates stability while covering high wattage and pulse loading.
- Materials in accordance with UL94-V0

### Specifications

- Resistance Values: 0.5Ω to 1MΩ (others upon request)
- Resistance Tolerance: ±5% to ±10%
- Temperature Coefficient: ±150ppm/°C (others upon request)
- Maximum Working Voltage: 5,000V DC, higher voltage on request, not exceeding max. power
- Short Time Overload: 1,000W at 70°C for 10sec., ΔR = 0.4% max. (for conf. 2 and 3)
- Power Rating: 600W at 85°C Bottom case temperature (others upon request)
- Peak Current: up to 1500 Amp. depending on pulse length and frequency Please ask for details
- Electric Strength Voltage: 6kVrms, 50Hz, upto 12kVrms on special request.
- Single Shot Voltage: up to 12 kV Normwave (1.5/50 μsec)
- Partial Discharge: 4kVrms, <10pC, up to 7kV on special request
- Insulation Resistance: 10GΩ Min. at 500V
- Inductance: - 80 nH
- Capacity/Mass: - 110 pF
- Capacity/Parallel: - 40 pF
- Operation Temperature: -55°C to +150°C
- Max. Torque for Mounting: 1.8 Nm M4 screws
- For pulse power details, please see page 33 (datasheet UXP-600)!

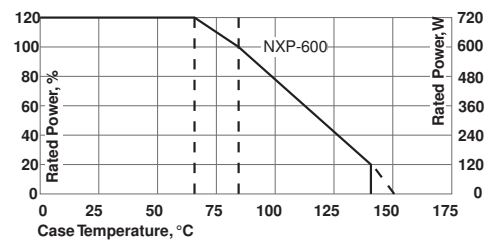
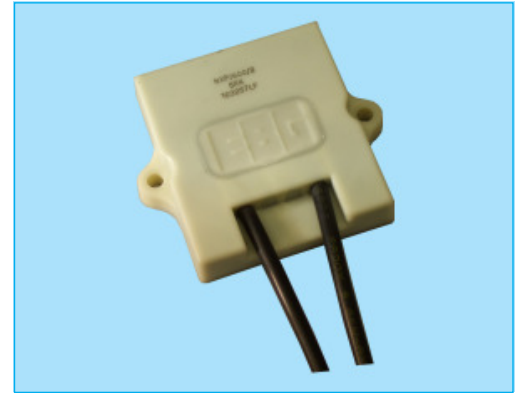

Derating (thermal resist.)

NXP 600: 8.33W/°K (0.12°K/W) (for conf. 2, 3)  
Power Rating: 600W at 85°C bottom case temp.\*

Please ask for detailed mounting procedure!

\* This value is only valid by using a thermal conduction to the heatsink  $R_{th-cs} < 0.025^{\circ}K/W$ . This value can be reached by using thermal transfer compound with a heat conductivity of 1W/mK. The flatness of the cooling plate must be better than 0.05mm overall. The roughness of the surface should not exceed 6.4μm.

### Configurations:

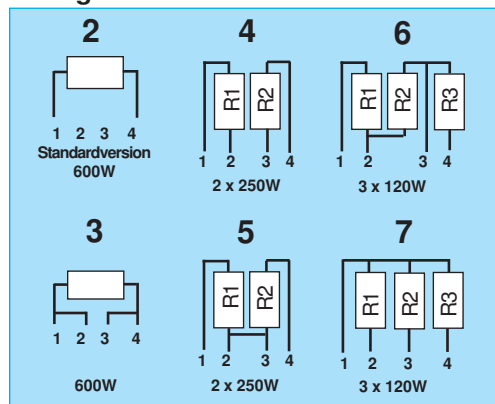

### Dimensions:

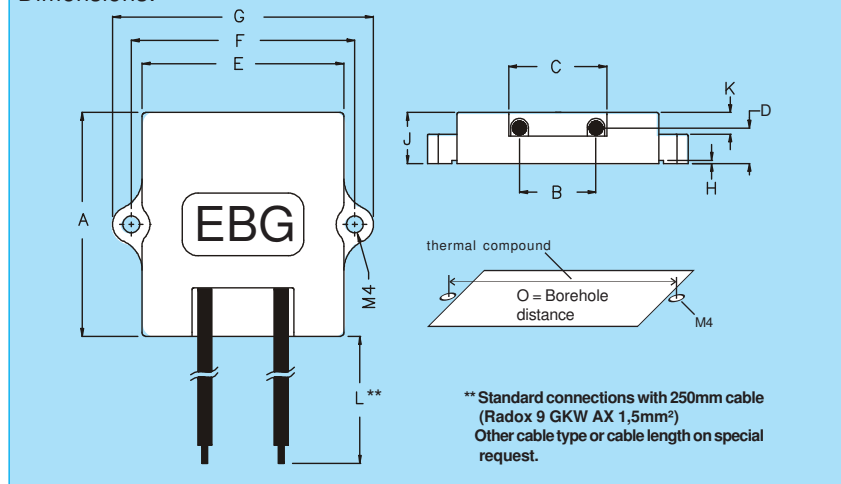

Test	Method	Typical Results
• Short time overload	1,000 W / 10sec (for 600W Element)	0.4%
• Humidity	56 days/40°C/95%	0.25%
• Temp. Steady State	-55/+125/5	0.20%
• Cycling	cycles	0.25%
• Shock	40g/4,000 times	0.25%
• Vibrations	2-500Hz/10g	0.40%
• Load Life	Ph 30 min. on/ 30 min off	

Dim.	Millimeter		Inches	
	Min.	Max	Min.	Max.
A	57.0	58.0	2.244	2.283
B	19.5	20.5	0.767	0.807
C	25.5	26.5	1.004	1.043
D	8.0	9.5	0.315	0.374
E	51.0	52.0	2.007	2.047
F	57.0	58.0	2.244	2.283
G	66.2	66.7	2.606	2.626
H	0.5	0.8	0.019	0.032
J	12.5	13.5	0.492	0.532
K	5.3	5.8	0.208	0.228
L	250	255	9.843	10.039
O	56.8	57.2	2.236	2.252

In the above spec sheet, you will find our standard product, please contact your local manufacturing representative or call us direct to find out details of other options available regarding this style. Please see our website for the most updated information!