

Series UPT 600

600 Watt Resistor, US Patent # 5,355,281

For variable speed drivers, power supplies, control devices, robotics, motor control and other power designs, the easy mounting fixture guarantees an autocalibrated pressure to the cooling plate of about 120 to 160 N.

Materials in accordance with UL94-V0

Specifications

- Resistance Values: 0.5Ω to 1MΩ
- Resistance Tolerance: ±5% to ±10%, tighter tolerances are available on request, with the reduction of the max. power / pulse rating. Please ask your local representative.
- Temperature Coefficient: ±150ppm/°C (others upon request)
- Maximum Working Voltage: 5,000V DC, higher voltage on request, not exceeding max. power
- Short Time Overload: 1,000W at 70°C for 10sec., ΔR = 0.4% max. (for conf. 2 and 3)
- Power Rating: up to 600W at 85°C bottom case temperature, see configurations
- Electric Strength Voltage: 6kVrms, 50Hz, up to 12kVrms or 23kV DC on special request.
- Dielectric Strength between R1 - R2 : > 5kV DC
- Single Shot Voltage: up to 12 kV Normwave (1.5/50 usec)
- Partial Discharge: 4kVrms, <10pC, up to 7kV on special request
- Insulation Resistance: 10GΩ Min. at 500V
- Inductance: - 80 nH
- Capacity/Mass: - 110 pF
- Capacity/Parallel: - 40 pF
- Operation Temperature: -55°C to +150°C
- Max. Torque for Contacts: 2 Nm
- Max. Torque for Mounting: 1.8 Nm M4 screws
- For pulse power details, please see page 32 (datasheet UXP-300), same as UXP-600, valid for configuration 2 and 3. For other configurations please contact EBG.



Configurations: (P/package)

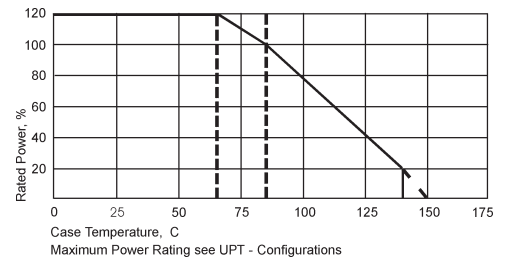
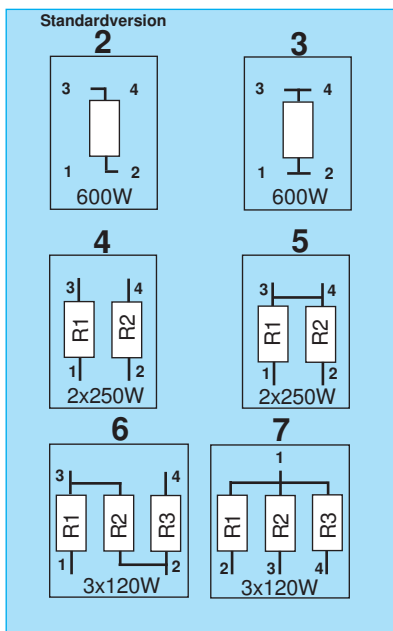

Derating (thermal resist.)
UPT 600: 8.33W/°K (0.12°KW)
(for conf. 2 and 3)
Power Rating: 600W at 85°C bottom case temp.*

Please ask for detailed mounting procedure!

* This value is only valid by using a thermal conduction to the heatsink $R_{th-cs} < 0.025^{\circ}K/W$. This value can be reached by using thermal transfer compound with a heat conductivity of 1W/mK. The flatness of the cooling plate must be better than 0.05mm overall. The roughness of the surface should not exceed 6.4μm.

Dimensions:

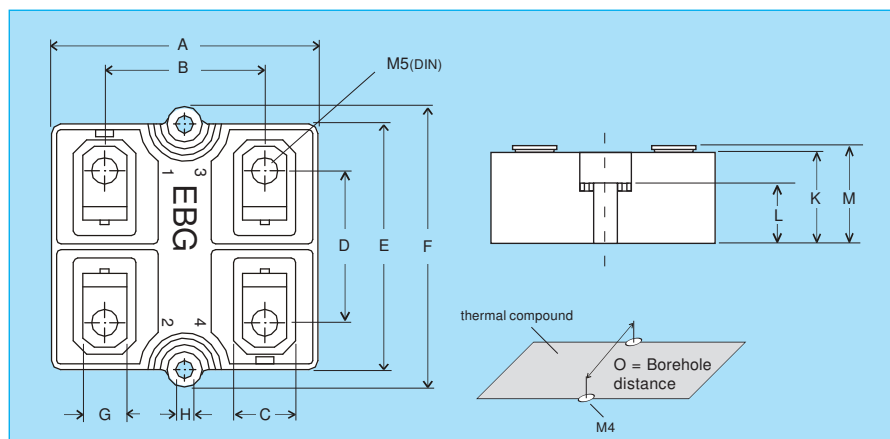

| Dim. | Millimeter | | Inches | |
|------|------------|------|--------|-------|
| | Min. | Max. | Min. | Max. |
| A | 59.2 | 60.8 | 2.331 | 2.394 |
| B | 35.8 | 36.2 | 1.409 | 1.425 |
| C | 13.5 | 14.5 | 0.531 | 0.571 |
| D | 33.8 | 34.2 | 1.331 | 1.346 |
| E | 57.0 | 58.0 | 2.244 | 2.283 |
| F | 64.2 | 65.8 | 2.527 | 2.591 |
| G | 9.5 | 10.5 | 0.374 | 0.413 |
| H | 4.05 | 4.3 | 0.159 | 0.169 |
| K | 24.0 | 25.0 | 0.945 | 0.984 |
| L | 14.5 | 15.5 | 0.571 | 0.610 |
| M | 25.5 | 26.5 | 1.004 | 1.043 |
| O | 56.8 | 57.2 | 2.236 | 2.252 |

In the above spec sheet, you will find our standard product, please contact your local manufacturing representative or call us direct to find out details of other options available regarding this style. Please see our website for the most updated information!